

Compressed Air Filters

KAESER FILTER

Flow rate 0.60 to 14.20 m³/min



KAESER FILTER

Pure compressed air with lowest costs

KAESER FILTER products are key components in delivering compressed air of all purity classes in accordance with ISO 8573-1 and they perform their duties with minimal pressure differential. Moreover, their service-friendly design not only ensures simple, error-free opening and closing of the filter housing, but also allows quick and clean element changes. KAESER FILTER products are available in four filter grades. Nine housing sizes provide efficient filtration for flow rates from 0.60 to 14.20 m³/min.

Standard purity

The KAESER FILTER range uses modern deep-pleated filter media to remove particles and aerosols. A highly effective carbon fibre mat traps oil vapours. Together with innovative through-flow, it delivers exceptional filtration efficiency with minimal pressure loss. The impressive performance data of KAESER FILTER products have been determined in accordance with ISO 12500 and confirmed by the independent testing agency "Lloyd's Register".

Minimal pressure loss, maximum savings

The efficiency of a compressed air filter depends most of all on pressure loss. KAESER FILTER products are characterised by generously dimensioned housings and filter surfaces, innovative through-flow and high performance filter media. These features result in up to 50 % less pressure loss in comparison to other typically available filters. In fact their filtration

performance remains virtually constant throughout their entire service life. This reduces the burden on upstream compressors and therefore provides significant cost and CO₂ savings potential.

Service-friendly design, safe handling

KAESER FILTER products feature a corrosion-resistant aluminium housing and a stable filter element. The practical bayonet lock ensures automatic positioning of the housing and element seals. Both seals are components of the filter element. This means that a filter housing can be sealed only if a filter element has been inserted. A stop screw prevents unintentional opening of the housing when under pressure and also provides housing venting.

Life cycle cost savings

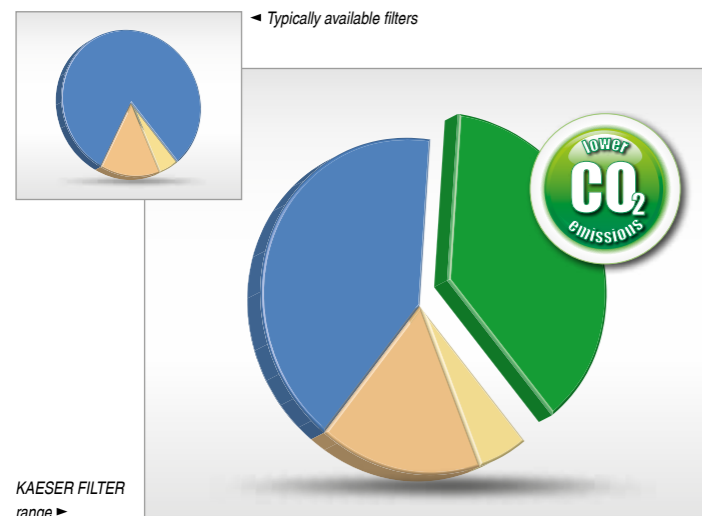
- Potential **energy cost savings** through system optimisation
- Compressed air filter investment
- Maintenance costs
- Energy costs

Coalescence filter example:
Flow rate 14.2 m³/min, 50 % reduced pressure loss, 6.55 kW/(m³/min), extra energy demand 6 % per bar, energy cost 0.2 €/kWh, 6000 operating hours per year, annual debt service over 10 years



- 1 Compressed air inlet
- 2 Connection flange, variable
- 3 Element head with housing and element seal
- 4 Filter element
- 5 Condensate outlet (here with automatic condensate drain)
- 6 Compressed air outlet
- 7 Stop screw
- 8 Bayonet lock with limit stop
- 9 Vent hole
- 10 Pressure differential gauge

Image: Coalescence filter layout and function

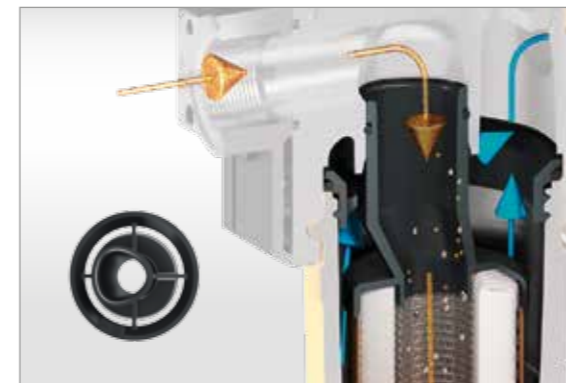




KAESER FILTER products are available in four efficient filter grades. All products in the range are exceptionally versatile and easily installed in combination with one another to suit the needs of the specific application. When used with compressed air dryers and air-main charging systems from KAESER, they ensure dependable and energy-efficient compressed air treatment where it's needed, when it's needed.

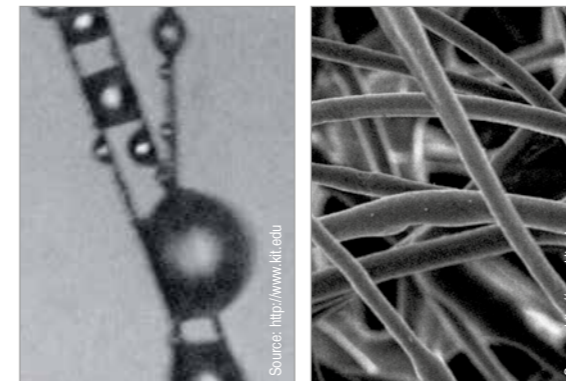
KAESER FILTER

Low differential pressure for maximum efficiency



Large flow cross-section

KAESER FILTER equipment uses filter elements with specially flow-optimised element heads. The filter inlet is offset towards the air inlet, which in turn increases the flow cross-section at the air discharge side and further contributes to outstanding filter efficiency with minimal pressure loss.



Low flow resistance

The advanced polyester material of the filter drainage layer ensures rapid and efficient oil drainage (left). Moreover, to achieve optimum filtration and contaminant retention with minimal pressure loss, KAESER particulate and coalescence filters feature high void volume filter media (right).



Minimised pressure losses

Generously-dimensioned connection flanges on KAESER FILTER products help keep pressure losses to an absolute minimum. Since KAESER FILTER products are available with air connection flanges of various sizes, there is no need for reducer sections when connecting to different air distribution networks.



Consistent efficiency

Fitted as standard to KAESER particle and coalescence filters, the differential pressure gauge enables users to check filter efficiency at a glance. Furthermore, the contaminant and clean air side are reliably isolated from one another.

KAESER FILTER

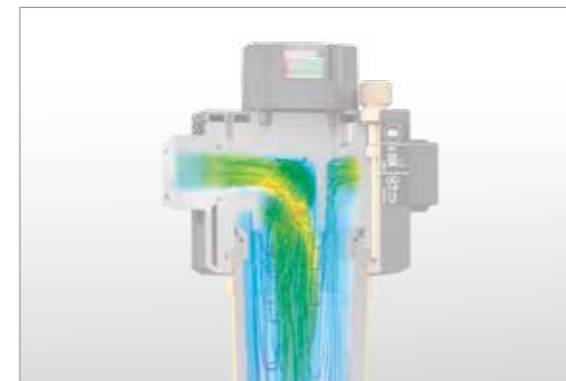
Standards-compliant purity in every quality class

Degree of filtration	KB Coalescence filter Basic	KE Coalescence filter Extra	KD Particulate filter Dust	KA Activated carbon filter Adsorption	KBE Extra Combination	KEA Carbon Combination
Initial differential pressure at saturation	< 140 mbar	< 200 mbar	< 30 mbar (New, dry)	< 35 mbar (New, dry)	< 200 mbar	< 240 mbar
Aerosol content at inlet	10 mg/m ³	10 mg/m ³	-	-	10 mg/m ³	10 mg/m ³
Remaining aerosol content at outlet as per ISO 12500-1*	< 0.1 mg/m ³	< 0.01 mg/m ³	-	-	< 0.01 mg/m ³	0.003 mg/m ³ (Total oil content)
Filter medium	Deep-pleated with support structure and polyester drainage fibre		Deep-pleated with support structure	High efficiency carbon fibre	-	-
Application	Filtration of solids, liquids, aerosols and particulate matter	Same field of use as for KB, but for higher compressed air quality	Exclusively for filtration of particulate matter	Exclusively for removal of oil vapours	Combination of KB and KE; field of use as for KE, but for higher assurance of compressed air quality	Combination of KE and KA; for filtration of aerosols, particulate matter and oil vapours

* as per ISO 12500-1:06-2007

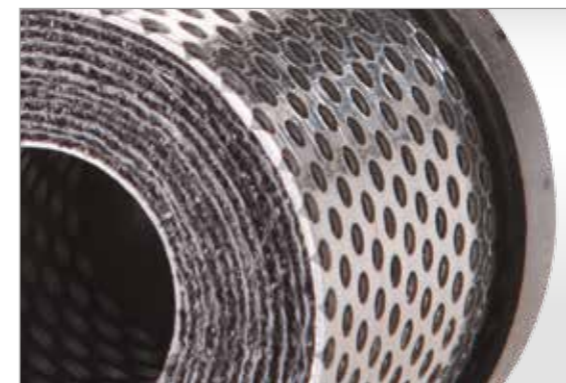


Image: Examples from the filter element range



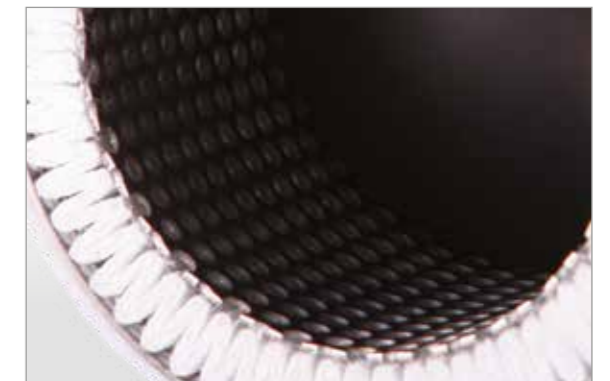
Optimum flow distribution

The element head of KAESER FILTER units is optimised for best possible through-flow. Its internal contour structure directs the compressed air centrally into the interior of the element in order to ensure even charging of the filter media. The result: high filtration efficiency with minimal pressure loss.



High efficiency carbon matting

Unlike the material used in conventional filters, the high efficiency carbon matting in KAESER activated carbon filters prevents channelling whilst also ensuring reduced differential pressure. Moreover, the matting provides highly effective protection against particle release.



Deep-pleated filter elements

The deep-pleated KAESER dust and coalescence filter elements feature exceptionally large filter surfaces. Through their resultant increased efficiency, they therefore significantly reduce operating costs compared to conventional filter designs.



Application-tailored combinations

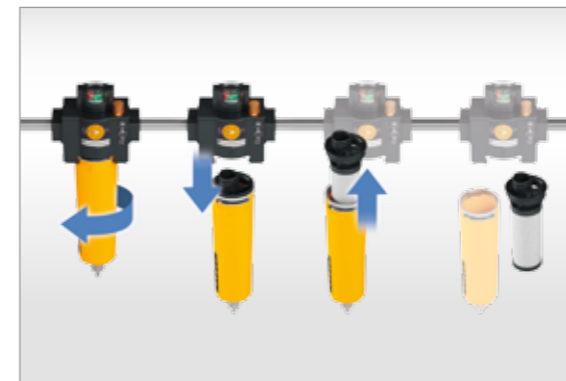
KAESER FILTER units can be flexibly combined on site with optional connection kits. For example, the "Carbon Combination" consisting of a KE coalescence filter (left) and a KA activated carbon filter (right) not only retains aerosols and particulate matter, but oil vapours also.



Image: Coalescence filter with ECO-DRAIN 31 F

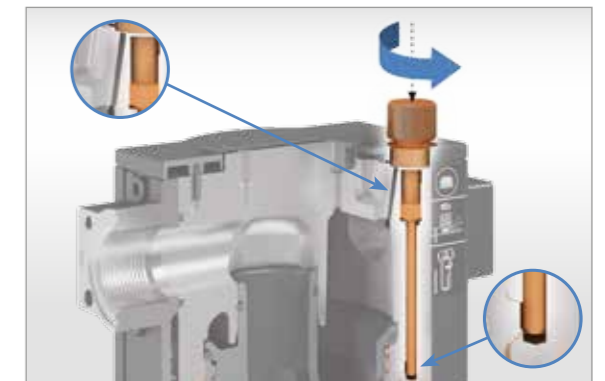
KAESER FILTER

Safe handling, service-friendly design



Easy element change

KAESER FILTER units can be easily opened by hand and are quick and clean to service. The filter element can simply be unscrewed once the filter housing with element is released from the head. Minimal installation space is required beneath the filter.



Safe opening

A stop screw protects the filter housing from unintentional opening. If released, a seal is broken and a vent hole subsequently comes into use. A warning venting sound can be heard if pressure is present.



Standard coating: Corrosion



KAESER: Zero corrosion

Corrosion-protected housing

KAESER filter housings are cast from high durability aluminium. Moreover, all cast aluminium parts are coated with an effective passivation layer for exceptional corrosion protection.



Normal expanded metal mesh



KAESER: Stable profiled metal

Stable stainless steel cages

KAESER filter elements are protected by inner and outer cages made from continuously welded sheet stainless steel. These cages are far more resistant to mechanical stress than those made from simple expanded metal.

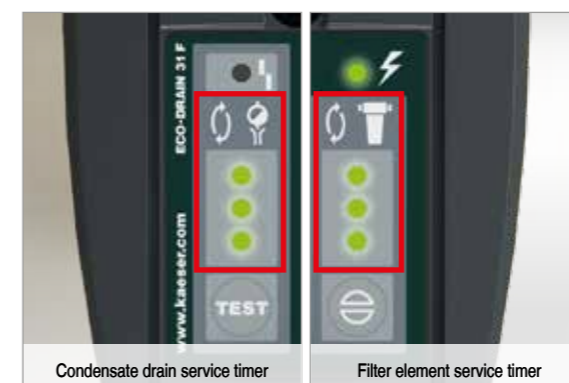


Image: Coalescence filter with ECO-DRAIN 31 F

KAESER FILTER

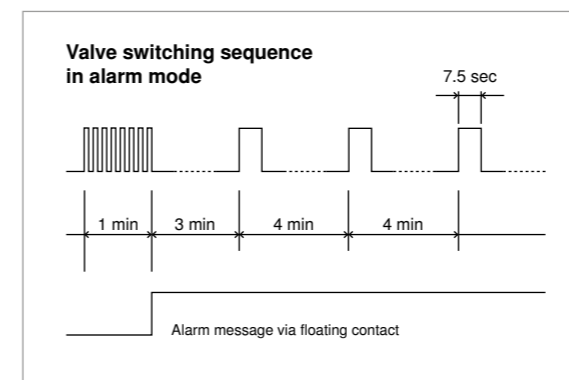
In order to ensure that the required grade of compressed air purity is consistently maintained, the filter elements should be replaced at the end of their service life. In addition, dependable condensate drainage is an essential part of reliable and environmentally-sound filtering out of aerosols.

The automatic **ECO-DRAIN 31 F** condensate drain was especially designed for use with coalescence filters – accumulating condensate is reliably removed without pressure loss.



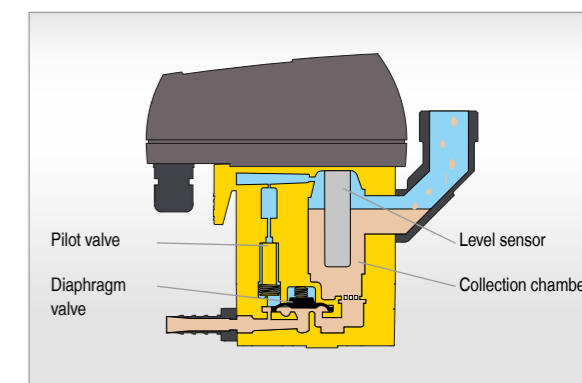
Service life monitoring

The ECO-DRAIN 31 F condensate drain not only monitors its own service interval but also that of the connected compressed air filter element. Service interval status is indicated via LEDs and a floating warning contact.



Self-monitoring

Should an issue with condensate drainage occur, the ECO-DRAIN valve opens in short cycles for 1 minute. If the condensate is not removed, a message is triggered and the valve then opens every 4 minutes for 7.5 seconds. Once the condensate is drained, the ECO-DRAIN reverts back to normal operation.



Dependable and loss-free

With contact-free sensing, ECO-DRAIN condensate drains detect the condensate fill level and drain the condensate away via a pilot diaphragm valve without pressure loss. Thanks to large flow cross sections, the use of maintenance-intensive strainers is not necessary.



Tested for leaks and functionality

All wear components of the ECO-DRAIN 31 F can be replaced simply by exchanging the service unit; there is no need to install a new seal. To ensure trouble-free maintenance, the condensate drain and service unit are meticulously checked at the factory for perfect functionality and sealing.

Degree of filtration	ECO-DRAIN 31 F	ECO-DRAIN 30	Automatic condensate drain	Manual condensate drain	Mechanical differential pressure gauge
KE	Selectable	Selectable	Selectable	–	Standard
KB	Selectable	Selectable	Selectable	–	Standard
KD	–	–	–	Standard	Standard
KA	–	–	–	Standard	–

Optimum air quality for your applications



Equipment



Image 1: KB/KE

Image 2: KB/KE

Image 3: KB/KE

Image 4: KD

Image 5: KA

Image 6: ECO DRAIN 30

Image 7: ECO-DRAIN 31 F

Coalescence filter with ECO-DRAIN 31 F

Corrosion-protected, coated aluminium housing with connection flanges (configurable nominal widths); stop screw; differential pressure gauge and rotatable angle ball valve (components installed complete); KB or KE filter element, as well as ECO-DRAIN 31 F electronic condensate drain with maintenance management (included) – **Image 1**

Coalescence filter with ECO-DRAIN 30

Corrosion-protected, coated aluminium housing with connection flanges (configurable nominal widths); stop screw; differential pressure gauge and rotatable

angle ball valve (components installed complete); KB or KE filter element and ECO-DRAIN 30 electronic condensate drain (included) – **Image 2**

Coalescence filter with automatic condensate drain

Corrosion-protected, coated aluminium housing with connection flanges (configurable nominal widths); stop screw; differential pressure gauge and automatic condensate drain (components installed complete); KB or KE filter element (included) – **Image 3**

Dust filter

Corrosion-protected, coated aluminium housing with connection flanges (configurable nominal widths); stop screw; differential pressure gauge and manual condensate drain (components installed complete); KD filter element (included) – **Image 4**

Activated carbon filter

Corrosion-protected, coated aluminium housing with connection flanges (configurable nominal widths); stop screw; differential pressure gauge, manual condensate drain (components installed complete); KA filter element (included) – **Image 5**

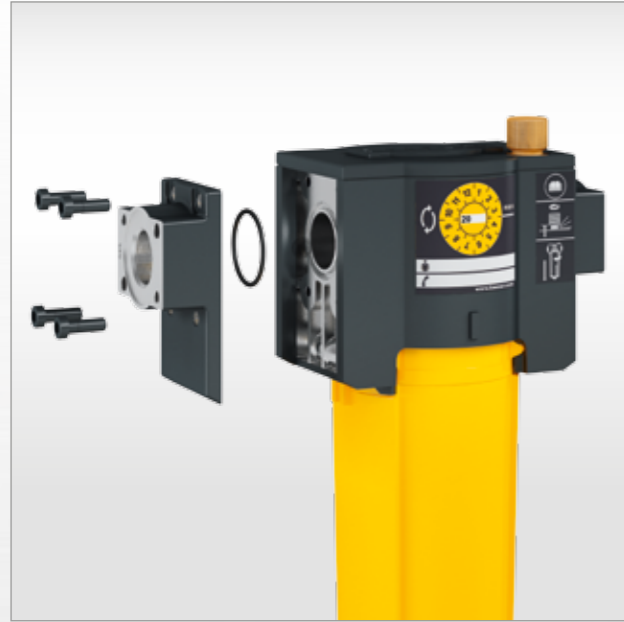
ECO DRAIN 30

Ensures exceptionally safe, reliable condensate drainage without compressed air loss - even under conditions with widely fluctuating condensate accumulation and high particulate / oil content; simple function monitoring at the touch of a button; service unit 100% works-tested for easy, trouble-free maintenance – **Image 6**

ECO-DRAIN 31 F

For use with aerosol filters; ensures exceptionally safe, reliable condensate drainage without compressed air loss; maintenance management system displays elapsed replacement interval for the filter element and service unit (via LED); message for elapsed replacement intervals provided via floating service contact; additional floating contact to relay alarm; function test button – **Image 7**

Additional options



Various connection sizes

The different sizes of housing models for KAESER FILTER units are available with factory-installed connection flanges of various nominal sizes. Furthermore, there is a choice of BSP and NPT threaded connections.

KAESER FILTER units can therefore be adapted to suit the sizing of the respective pipe distribution network without the need for reducer sections.



Silicone-free version

KAESER FILTER products also include optionally available silicone-free versions that are compliant with test standard PV-VW 3.10.7. Each filter is subjected to an individual coating test to confirm compliance; the supplied manufacturer's certificate attests that the product is silicone-free. Moreover, all filter elements for KAESER FILTER products are manufactured to be silicone-free in accordance with this regulation as standard.



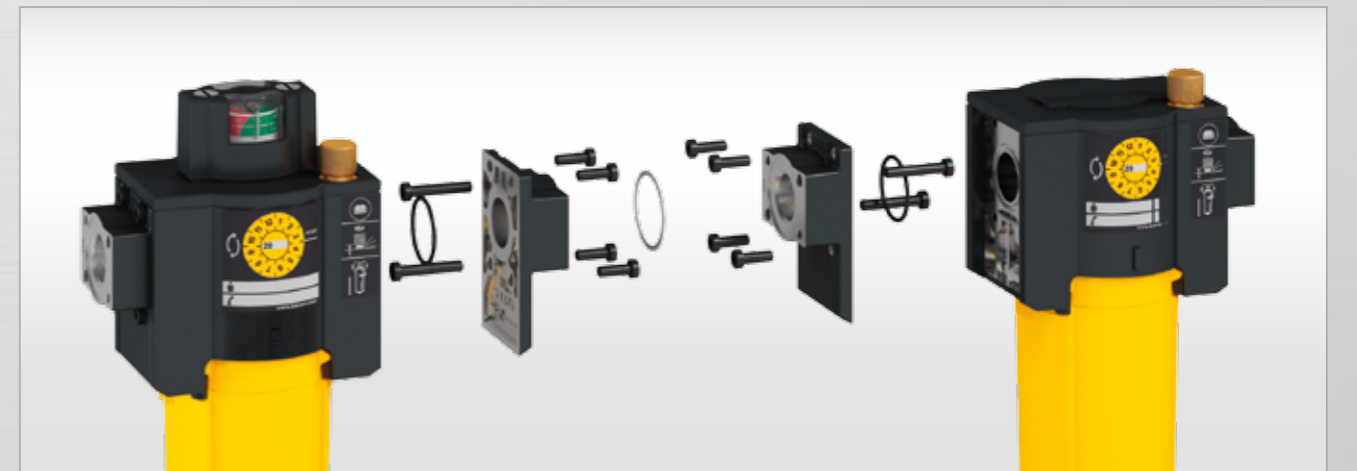
Accessories



Convenient wall-mounting kit

Convenient and stable wall-mounting brackets are available as an optional accessory for KAESER FILTER units – they attach easily to the connection flanges.

A kit that enables mounting of filter combinations comprising up to a maximum of three filters is also offered. The installation tool required to enable attachment to the filter head is included.



Connection kit

Multiple KAESER FILTER units can be easily combined on-site using the optionally available connection kit. The kit also includes the necessary screws, a seal and the installation tool.

Technical specifications

Model	Flow rate m³/min	Compressed air connection (Option) G	Gauge pressure bar	Ambient temperature °C	Inlet temperature Compressed air °C	Maximum mass KG	Electrical supply ECO-DRAIN
F6	0.60	¾ (½, ¾)	2 to 16	+3 to +50	+3 to +66	3.3	95...240 VAC ±10% (50...60 Hz) / 100...125 VDC ±10%
F9	0.90					3.3	
F16	1.60	1 (¾)	2 to 16	+3 to +50	+3 to +66	4.0	
F22	2.20					4.2	
F26	2.60					4.3	
F46	4.61	2 (1½, 1¼)	2 to 16	+3 to +50	+3 to +66	8.2	
F83	8.25					9.1	
F110	11.00					10.7	
F142	14.20					11.1	

Performance data at 7 bar gauge pressure based on 1 bar ambient pressure absolute and 20 °C. The flow rate differs for deviating operating conditions. G compressed air connections as per ISO 228, optional NPT connections as per ANSI B 1.20.1

Dimensions

Model	A G	B mm	C mm	D mm	E mm	F mm	G mm	H mm		
F6	¾ (½, ¾)	283	308	232	155	87	90	≥ 40		
F9								≥ 40		
F16	1 (¾)	315	340	259	164	98	100	≥ 40		
F22								≥ 40		
F26								≥ 40		
F46	2 (1½, 1¼)	386	411	312	237	153	130	≥ 50		
F83								≥ 50		
F110								≥ 50		
F142								671	696	597

G compressed air connections as per ISO 228, alternatively NPT as per ANSI B 1.20.1

Calculating flow rate

Correction factors for deviating operating conditions (flow rates in m³/min x k...)

Deviating working pressure p at filter inlet															
p bar _(g)	2	3	4	5	6	7	8	9	10	11	12	13	14	15	16
k _p	0.38	0.50	0.63	0.75	0.88	1.00	1.06	1.12	1.17	1.22	1.27	1.32	1.37	1.41	1.46

Example:

Gauge pressure: 10 bar(g) (See table) k_p = 1.17

Chosen compressed air filter F 83 with 8.25 m³/min (V_{Reference})

Max. possible flow rate under operating conditions

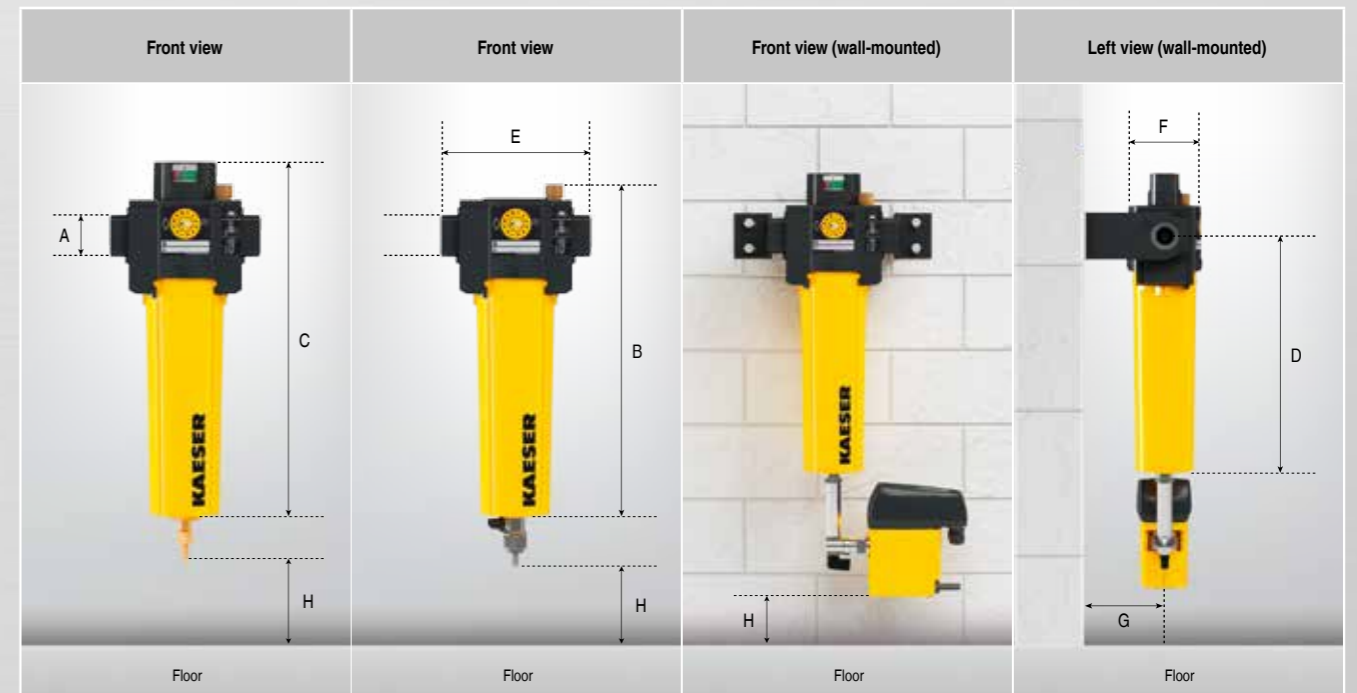
$V_{Max\ Operation} = V_{Reference} \times k_p$

$V_{Max\ Operation} = 8.25 \text{ m}^3/\text{min} \times 1.17 = 9.65 \text{ m}^3/\text{min}$



Views

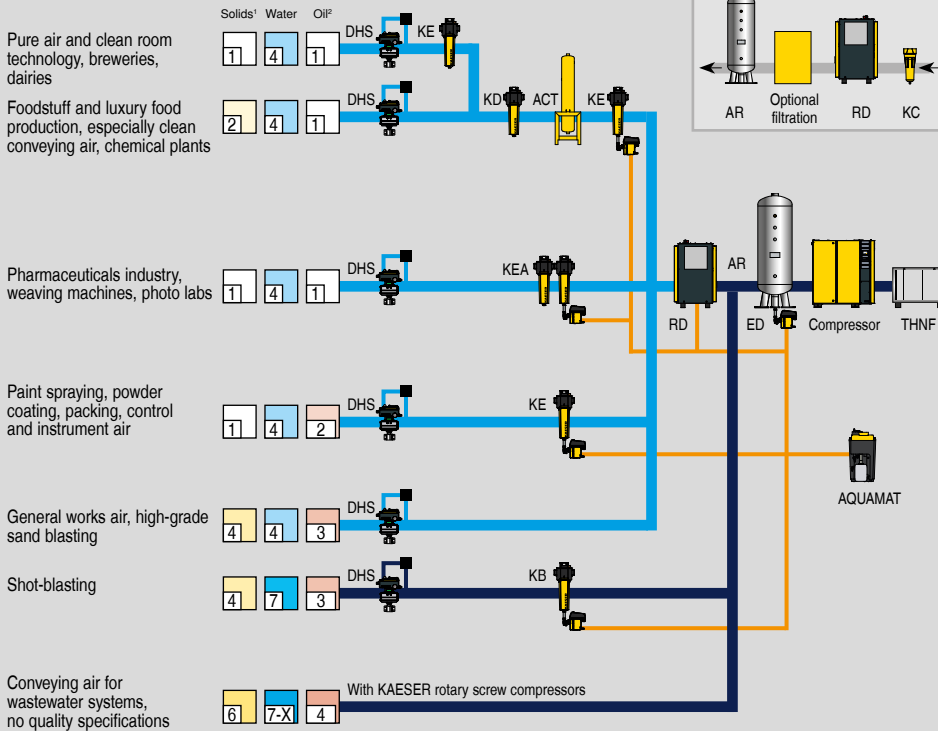
Models shown F16/F22/F26



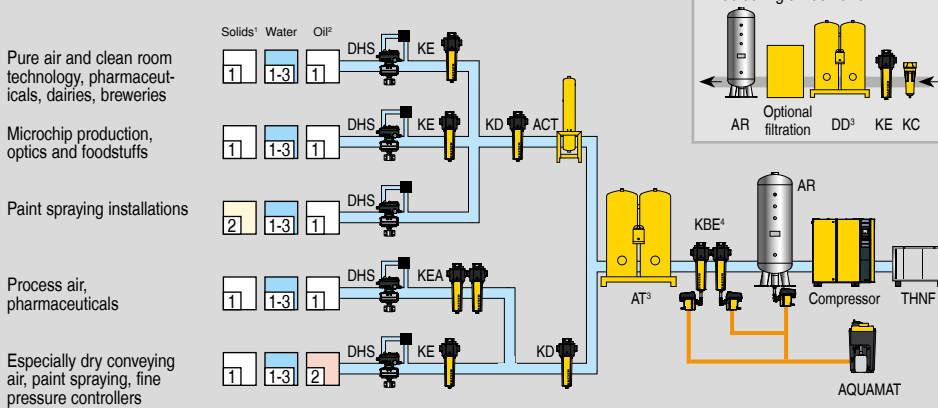
Choose the required grade of treatment according to your field of application:

Examples: Selection of treatment classes to ISO 8573-1 (2010)

Air treatment with refrigeration dryer



Compressed air treatment with desiccant dryer



¹⁾ Achievable particle class with expert-implemented pipework and commissioning.
²⁾ Achievable total oil content with use of recommended compressor oils and unloaded intake air.
³⁾ High temperature filters and possibly an aftercooler are required downstream from heat-regenerated desiccant dryers.
⁴⁾ The use of an 'Extra Combination' (a filter combination comprising a KB and downstream KE filter) is recommended for critical applications requiring exceptionally high compressed air purity (e.g. in the electronics and optics sectors).

	Explanation
ACT	Activated carbon adsorber
AQUAMAT	AQUAMAT
DD	Desiccant dryer
DHS	Air-main charging system
AR	Air receiver
ED	ECO-DRAIN
KA	Activated carbon filter, adsorption
KB	Coalescence filter, Basic
KBE	Extra Combination
KD	Particulate filter, dust
KE	Coalescence filter, Extra
KEA	Carbon Combination
RD	Refrigeration dryer
THNF	Bag filter
KC	Centrifugal separator

Compressed air quality classes to ISO 8573-1(2010):

Solid particles/dust			
Class	Max. particle count per m ³ * of a particle size d in [µm]		
	0.1 ≤ d ≤ 0.5	0.5 ≤ d ≤ 1.0	1.0 ≤ d ≤ 5.0
0	Please consult KAESER regarding specific requirements		
1	≤ 20,000	≤ 400	≤ 10
2	≤ 400,000	≤ 6,000	≤ 100
3	Not defined	≤ 90,000	≤ 1,000
4	Not defined	Not defined	≤ 10,000
5	Not defined	Not defined	≤ 100,000
Particle concentration C _p in mg/m ³ *			
6	0 < C _p ≤ 5		
7	5 < C _p ≤ 10		
X	C _p > 10		

Water	
Class	Pressure dew point, in °C
0	Please consult KAESER regarding specific requirements
1	≤ -70 °C
2	≤ -40 °C
3	≤ -20 °C
4	≤ +3 °C
5	≤ +7 °C
6	≤ +10 °C
Concentration of liquid water C _w in g/m ³ *	
7	C _w ≤ 0.5
8	0.5 < C _w ≤ 5
9	5 < C _w ≤ 10
X	C _w > 10

Oil	
Class	Total oil concentration (fluid, aerosol + gaseous) mg/m ³ *
0	Please consult KAESER regarding specific requirements
1	≤ 0.01
2	≤ 0.1
3	≤ 1.0
4	≤ 5.0
X	> 5.0

*) With reference conditions 20°C, 1 bar(a), 0% humidity



KAESER KOMPRESSOREN SE

P.O. Box 2143 – 96410 Coburg – GERMANY – Tel +49 9561 640-0 – Fax +49 9561 640-130
 e-mail: productinfo@kaeser.com – www.kaeser.com